

WISKUNDE OEFEN EN VRAESTELBOEK



GRAAD 6

KABV

Nienke Nieuwenhuizen



Inhoudsopgawe

	Oefening	Antwoorde	
1	Tel, rangskik en vergelyk heelgetalle	2	162
2	Getalsinne	6	164
3	Optel en aftrek	7	165
4	Gewone breuke	16	169
5	Tyd	28	176
6	2D vorms	36	180
7	Datahantering	41	182
8	Numeriese en meetkundige patrone	48	184
9	Vermenigvuldiging en deling	50	185
10	3D voorwerpe	65	196
11	Simmetrie	69	198
12	Desimale	70	198
13	Kapasiteit en volume	78	205
14	Massa	85	209
15	Aansigte	91	213
16	Transformasies	93	213
17	Persentasies	98	216
18	Temperatuur	102	218
19	Lengte	104	218
20	Omtrek, oppervlakte, volume en buite oppervlakte	111	222
21	Posisie en beweging	116	226
22	Waarskynlikheid	117	226
	Oefenvraestel kwartaal 1	118	227
	Oefenvraestel kwartaal 2	129	232
	Oefenvraestel kwartaal 3	138	237
	Oefenvraestel kwartaal 4	150	244

OEFENING 1: TEL, RANGSKIK, VERGELYK EN STEL HEELGETALLE VOOR

1. Skryf die plekwaarde van elke getal in:

1.1 14 826 369

1.2 228 332 698

2. Skryf die getalwaarde van elke getal in:

2.1 36 592 356

2.2 987 535 236

3. Skryf die volgende getalle in uitgebreide notasie

3.1 56 219 589

3.2 669 526 285

4. Rond af tot die naaste 5

4.1 12 111 539 : _____

4.2 33 221 325 : _____

4.3 69 835 232 : _____

4.4 65 446 221 : _____

4.5 32 555 238 : _____

4.6 369 611 353 : _____

4.7 365 152 566 : _____

4.8 222 333 111 : _____

4.9 369 199 234 : _____

4.10 999 999 987 : _____

OEFENING 2: GETALSINNE

1. Voltooi die volgende getalsinne:

1.1 $15 + 23 = \underline{\quad}$ $\underline{\quad} - 23 = 15$ $\underline{\quad} - 15 = \underline{\quad}$

1.2 $100 + 43 = \underline{\quad}$ $\underline{\quad} - 100 = 43$ $\underline{\quad} - 43 = \underline{\quad}$

1.3 $205 - 56 = \underline{\quad}$ $\underline{\quad} + 56 = \underline{\quad}$ $149 + \underline{\quad} = 205$

1.4 $159 - 88 = \underline{\quad}$ $\underline{\quad} + 88 = 159$ $71 + \underline{\quad} = 159$

1.5 $3 \times 8 = \underline{\quad}$ $\underline{\quad} \div 8 = 3$ $\underline{\quad} \div 3 = 8$

1.6 $4 \times 9 = \underline{\quad}$ $\underline{\quad} \div 4 = 9$ $\underline{\quad} \div 9 = 4$

1.7 $45 \div 5 = \underline{\quad}$ $\underline{\quad} \times 5 = 45$ $9 \times \underline{\quad} = 45$

1.8 $30 \div 6 = \underline{\quad}$ $\underline{\quad} \times 6 = 30$ $5 \times \underline{\quad} = 30$

1.9 $1\ 115 + \underline{\quad} = 1\ 130$

1.10 $2\ 005 + \underline{\quad} = 2\ 556$

1.11 $3\ 395 + \underline{\quad} = 4\ 445$

1.12 $1\ 199 + \underline{\quad} = 2\ 525$

1.13 $2500 + \underline{\quad} = 3\ 009$

1.14 $3\ 012 - \underline{\quad} = 2\ 090$

1.15 $2\ 060 - \underline{\quad} = 1\ 599$

1.16 $4\ 895 - \underline{\quad} = 3\ 599$

1.17 $5\ 999 - \underline{\quad} = 4\ 000$

1.18 $4\ 596 - \underline{\quad} = 3\ 256$

1.19 $5 \times \underline{\quad} = 20$

1.20 $6 \times \underline{\quad} = 30$

1.21 $7 \times \underline{\quad} = 70$

1.22 $10 \times \underline{\quad} = 100$

1.23 $2 \times \underline{\quad} = 20$

1.24 $50 \div \underline{\quad} = 5$

1.25 $60 \div \underline{\quad} = 20$

1.26 $25 \div \underline{\quad} = 5$

1.27 $20 \div \underline{\quad} = 5$

1.28 $22 \div \underline{\quad} = 11$

OEFENING 3: OPTEL EN AFTREK

1.	HD	TD	D	H	T	E
	1	1	2	1	0	2
+	6	8	7	4	5	7

2.	HD	TD	D	H	T	E
	2	5	9	5	7	2
+	3	1	0	4	1	0

3.	HD	TD	D	H	T	E
	5	6	8	2	3	2
+	1	1	1	1	1	1

4.	HD	TD	D	H	T	E
	2	3	6	5	1	2
+	5	5	0	0	5	5

5.	HD	TD	D	H	T	E
	1	2	4	5	2	2
+	5	2	4	4	2	3

6.	HD	TD	D	H	T	E
	3	2	5	6	7	1
+	2	5	4	3	1	5

7.	M	HD	TD	D	H	T	E
	2	3	5	1	2	6	2
+	2	2	2	1	5	3	2

8.	M	HD	TD	D	H	T	E
	2	3	6	5	1	2	3
+	3	6	2	4	1	2	1

9.	M	HD	TD	D	H	T	E
	8	9	5	4	5	4	4
+	1	0	4	5	4	5	5

10.	M	HD	TD	D	H	T	E
	4	1	2	3	6	5	8
+	5	4	6	2	1	4	1

11.	M	HD	TD	D	H	T	E
	2	1	5	3	6	5	2
+	1	2	0	6	3	2	1

12.	M	HD	TD	D	H	T	E
	2	5	6	9	5	2	3
+	3	0	3	0	1	2	5

13.	HD	TD	D	H	T	E
	8	5	9	8	5	5
+	8	5	9	8	5	4

14.	HD	TD	D	H	T	E
	8	9	8	8	8	8
+	5	8	9	5	4	2

15.	HD	TD	D	H	T	E
	5	8	9	5	2	5
+	8	9	8	5	2	5

16.	HD	TD	D	H	T	E
	5	8	9	5	6	2
+	5	9	8	5	2	5

25.	HD	TD	D	H	T	E
	5	6	8	2	3	2
-	1	1	1	1	1	1

26.	HD	TD	D	H	T	E
	2	5	6	5	5	5
-	1	3	0	0	1	2

27.	HD	TD	D	H	T	E
	5	2	4	5	2	3
-	1	2	4	4	2	2

28.	HD	TD	D	H	T	E
	3	5	5	6	7	5
-	2	2	4	3	1	1

29.	M	HD	TD	D	H	T	E
	2	3	5	1	5	6	2
-	2	2	2	1	2	3	2

30.	M	HD	TD	D	H	T	E
	3	6	6	5	1	2	3
-	2	3	2	4	1	2	1

31.	M	HD	TD	D	H	T	E
	8	9	5	5	5	5	5
-	1	0	4	4	4	4	4

32.	M	HD	TD	D	H	T	E
	5	4	6	3	6	5	8
-	4	1	2	2	1	4	1

33.	M	HD	TD	D	H	T	E
	2	2	5	6	6	5	2
-	1	1	0	3	3	2	1

34.	M	HD	TD	D	H	T	E
	3	5	6	9	5	2	5
-	2	0	3	0	1	2	3

35.	HD	TD	D	H	T	E
	8	5	9	8	5	5
-	8	5	9	8	5	4

36.	HD	TD	D	H	T	E
	8	9	8	8	8	8
-	5	9	9	9	9	9

37.	HD	TD	D	H	T	E
	8	8	9	5	2	5
-	5	9	8	5	2	5

38.	HD	TD	D	H	T	E
	5	9	8	5	6	2
-	5	8	9	5	2	5

39.	HD	TD	D	H	T	E
	5	9	8	5	2	5
-	5	6	8	5	4	2

40.	HD	TD	D	H	T	E
	5	6	9	8	5	4
-	4	7	9	9	6	5

47. Daar woon 16 098 571 mense in Gauteng, 2 900 000 mense in die Vrystaat en 7 343 020 mense in die Wes-Kaap. Hoeveel mense bly daar altesaam in die drie provinsies?

48. Daar woon 5 142 216 mense in Mpumalanga, 6 015 000 mense in die Limpopo provinsie en 1 335 945 mense in die Noord-Kaap. Hoeveel mense bly daar altesaam in die drie provinsies?

49. 'n Fabriek maak 4 236 320 tablette in Januarie, 89 858 542 tablette in Februarie, 22 522 522 tablette in Maart en 5 988 988 tablette in April. Hoeveel maak hulle die res van die jaar as hulle altesaam 300 000 000 tablette maak?

50. 'n Welsynsorganisasie samel geld in om diere te help. April samel hulle R 10 234 200 in, Mei R 25 256 300, Junie R 13 325 300 en Julie R 45 223 025

50.1 Wat is die verskil tussen April en Mei se bedrag?

OEFENING 4: GEWONE BREUKE

1. Vul in kleiner as, groter as of gelyk aan:

$\frac{2}{3}$		$\frac{3}{4}$
$\frac{2}{3}$		$\frac{4}{7}$
$\frac{1}{2}$		$\frac{7}{9}$
$\frac{10}{11}$		$\frac{4}{7}$
$\frac{1}{5}$		$\frac{2}{10}$

2. Gee 'n ekwivalente breuk vir:

2.1 $\frac{4}{5} = \underline{\hspace{2cm}}$

2.2 $\frac{2}{5} = \underline{\hspace{2cm}}$

2.3 $\frac{1}{4} = \underline{\hspace{2cm}}$

2.4 $\frac{3}{10} = \underline{\hspace{2cm}}$

2.5 $\frac{5}{8} = \underline{\hspace{2cm}}$

3. Skryf die volgende gemengde getalle as onegte breuke:

3.1 $5\frac{1}{2} = \underline{\hspace{2cm}}$

3.2 $4\frac{1}{3} = \underline{\hspace{2cm}}$

3.3 $3\frac{1}{4} = \underline{\hspace{2cm}}$

3.4 $4\frac{1}{2} = \underline{\hspace{2cm}}$

3.5 $5\frac{1}{4} = \underline{\hspace{2cm}}$

OEFENING 5: TYD

1. Skryf die tyd by elke horlosie in analoog tyd en digitale tyd:

1.1

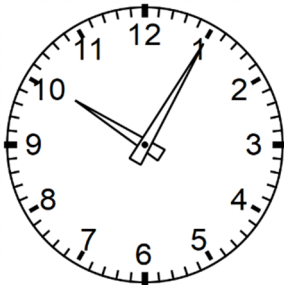

1.2

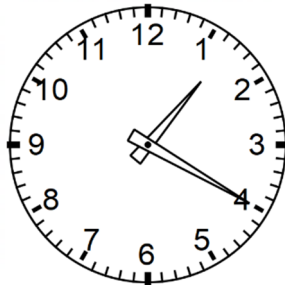

1.3

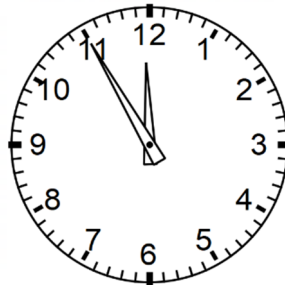

1.4



1.5

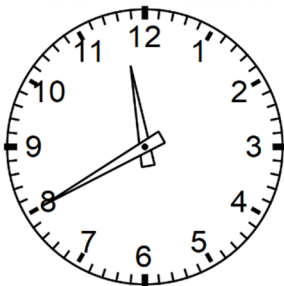

1.6

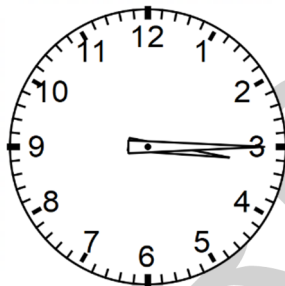

1.7

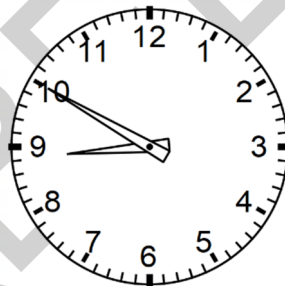

1.8

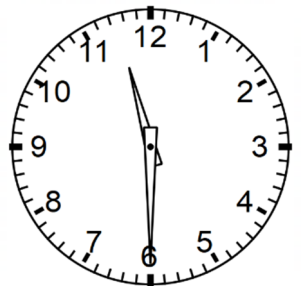

1.9

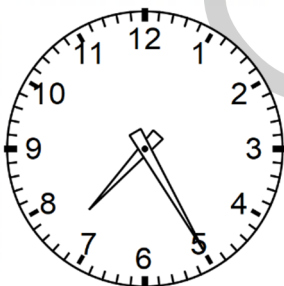

1.10

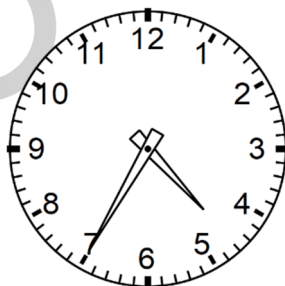

1.11

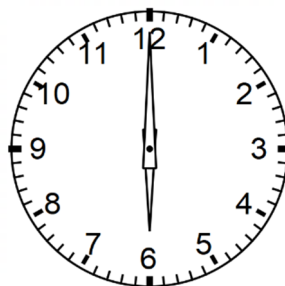



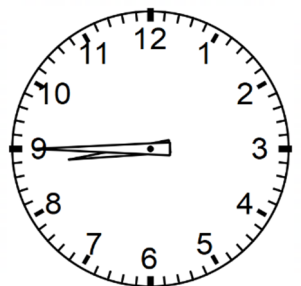



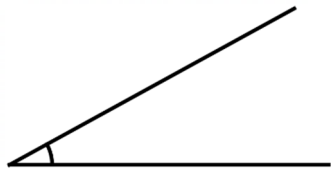
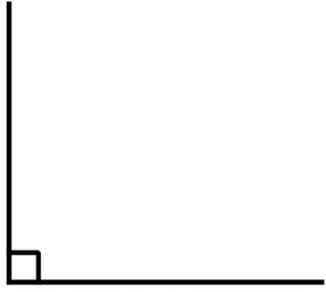
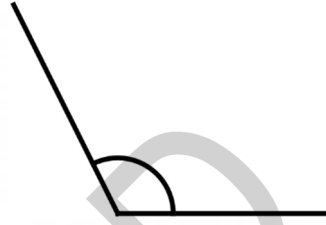

1.12

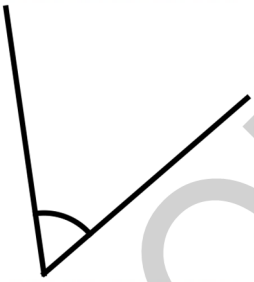

OEFENING 6: 2D VORMS

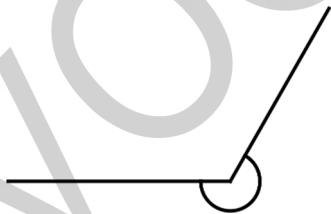
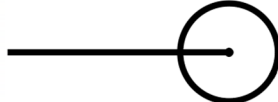
1. Skryf die naam van elke hoek onder die betrokke skets.

		
_____	_____	_____
		
_____	_____	_____
		
_____	_____	_____
		
_____	_____	_____

OEFENING 7: DATAHANTERING

1. Teken 'n staafgrafiek vir die volgende data:

Watter kleur oë het kinders?

Kleur oë	Telmerkies	Frekwensie
Bruin	HHH III	8
Blou	IIII	4
Groen	HHH III	8
TOTAAL		20

VOORBEELD



Kopiereg 2023

www.wiskundewenners.co.za

0835795369

